



**Politecnico
di Torino**
International
University

Efficientamento energetico e riduzione dei consumi idrici in un impianto di produzione di anidride solforosa

Progetto di Ricerca e Sviluppo finanziato
dal Bando SWIch – Regione Piemonte



A COMPANY OF ESSECO INDUSTRIAL

ESSECO INDUSTRIAL



 **1.300**
DIPENDENTI

 PRESENTE IN
18 PAESI

4^a GENERAZIONE
di imprenditori presenti
(e la quinta in formazione)

100 ANNI
di storia imprenditoriale
e di passione industriale



**GOVERNANCE
BILANCIATA**
con una forte delega
manageriale e una solida
struttura imprenditoriale

**CHIMICA
RESPONSABILE**
Ne rendiamo possibile
lo sviluppo ogni giorno





-  ESSECO
-  ESSECO BRASIL
-  ESSECO FRANCE
-  ESSECO MEXICO
-  ESSECO UK
-  ESSECO USA



-  ALTAIR CHEMICAL
-  ALTAIR CHIMICA IBERICA



-  ADDCON GERMANY
-  ADDCON NORDIC
-  ADDCON DALIAN



ESSECO INDUSTRIAL

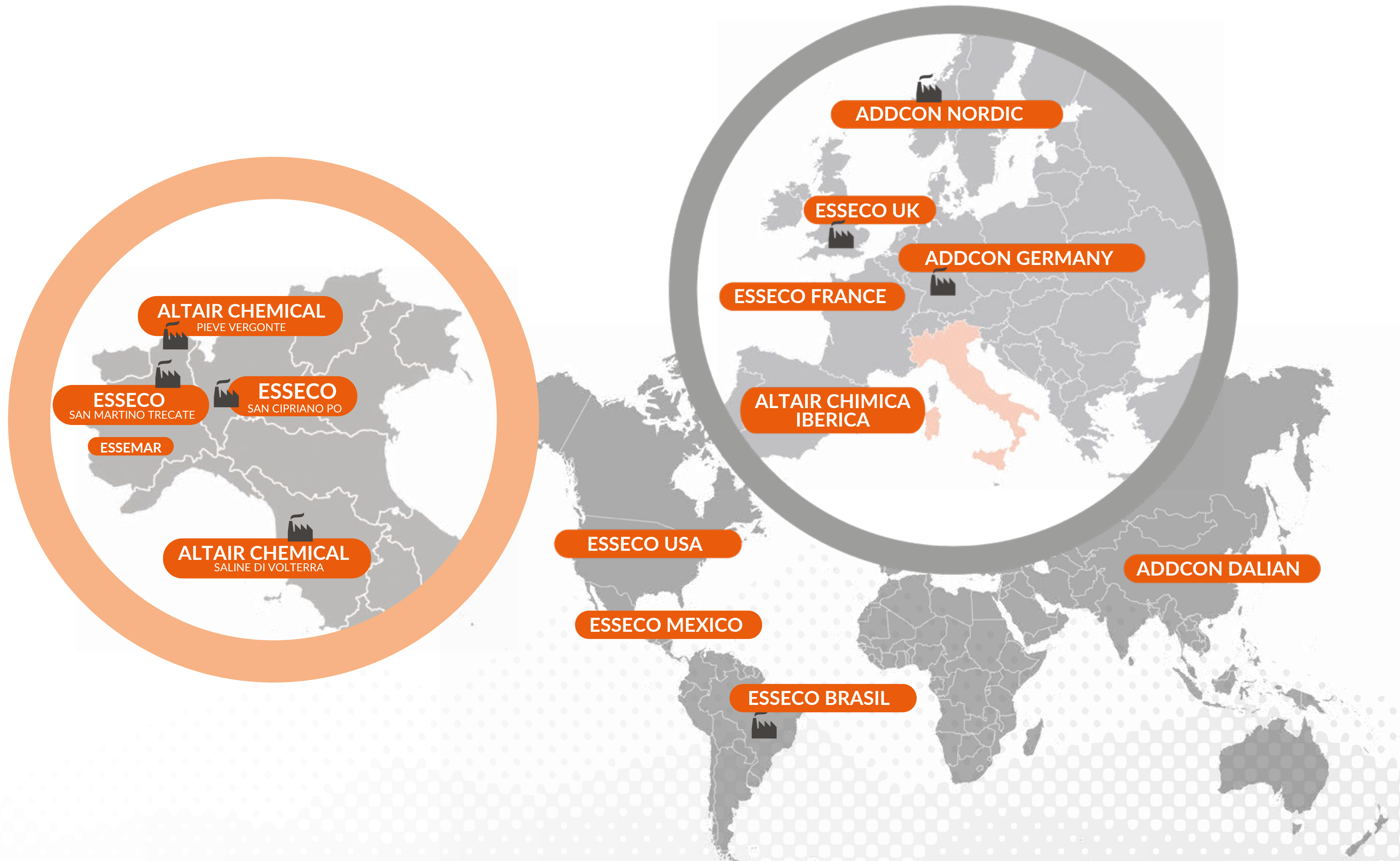

~725
DIPENDENTI

2.500
CLIENTI

FATTURATO
>550 M€
TRIENNIO 22/24



I NOSTRI SITI PRODUTTIVI ITALIANI



SALINE DI VOLTERRA (PI)



PIEVE VERGONTE (VB)



**PRODUZIONI
CLORO-ALCALI
E DERIVATI**



**PRODUZIONI
CLORO-ALCALI
E DERIVATI**



FATTURATO MEDIO
TRIENNIO SOCIETÀ

€ 294 mln



DIPENDENTI
SOCIETÀ

188



SAN MARTINO DI TRECATE (NO)



**PRODUZIONI
PRODOTTI CHIMICI
A BASE DI ZOLFO
E DERIVATI**



SAN CIPRIANO PO (PV)



**PRODUZIONI
PRODOTTI CHIMICI
A BASE DI ZOLFO
E DERIVATI**



FATTURATO MEDIO
TRIENNIO SOCIETÀ

€ 175 mln



DIPENDENTI
SOCIETÀ

250



LA NOSTRA ENERGIA



DATI ENERGETICI 2024



97% ENERGIA CO₂ FREE

100% ENERGIA PRODOTTA

*Energia con garanzie d'origine green



TURBINA A VAPORE

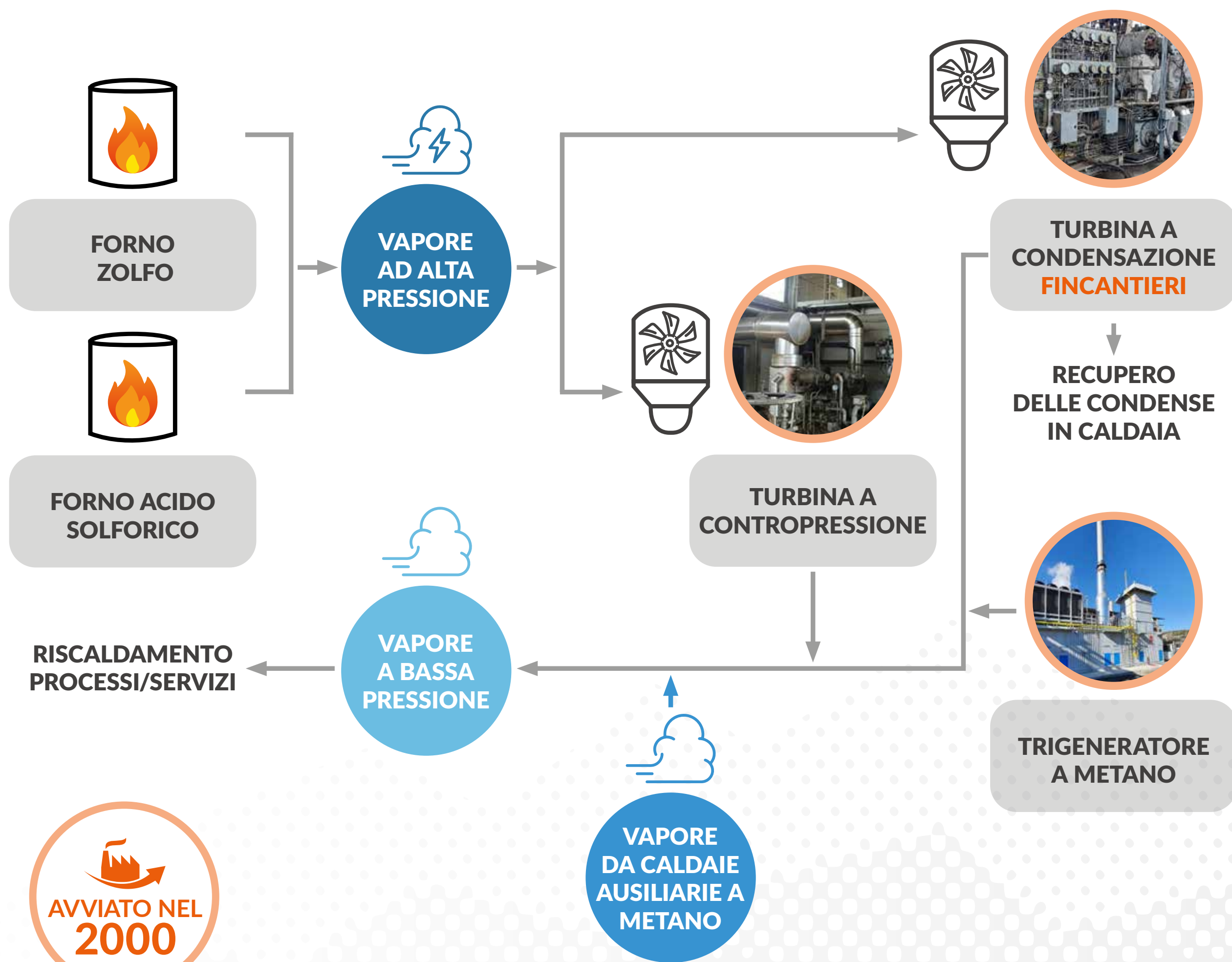

AVVIATO NEL
2000

Gli impianti sono realizzati per **ottimizzare i consumi energetici, recuperando energia termica ed elettrica** riducendo le emissioni di CO₂.

La turbina a condensazione ha una capacità produttiva di **5,4 MWh** corrispondenti a **21 t/ora di vapore ad alta pressione (500 t/giorno)** CO₂ free.

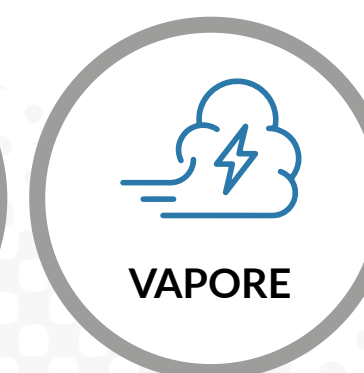

BREVETTO SHS



Il nuovo impianto di produzione SHS è stato il primo prototipo sviluppato e installato seguendo il brevetto Esseco. Il ditionito di sodio (SHS) è un importante agente riducente utilizzato nell'industria chimica, tessile e della carta. Il brevetto ESSECO (2016-2017) delinea un processo produttivo innovativo.

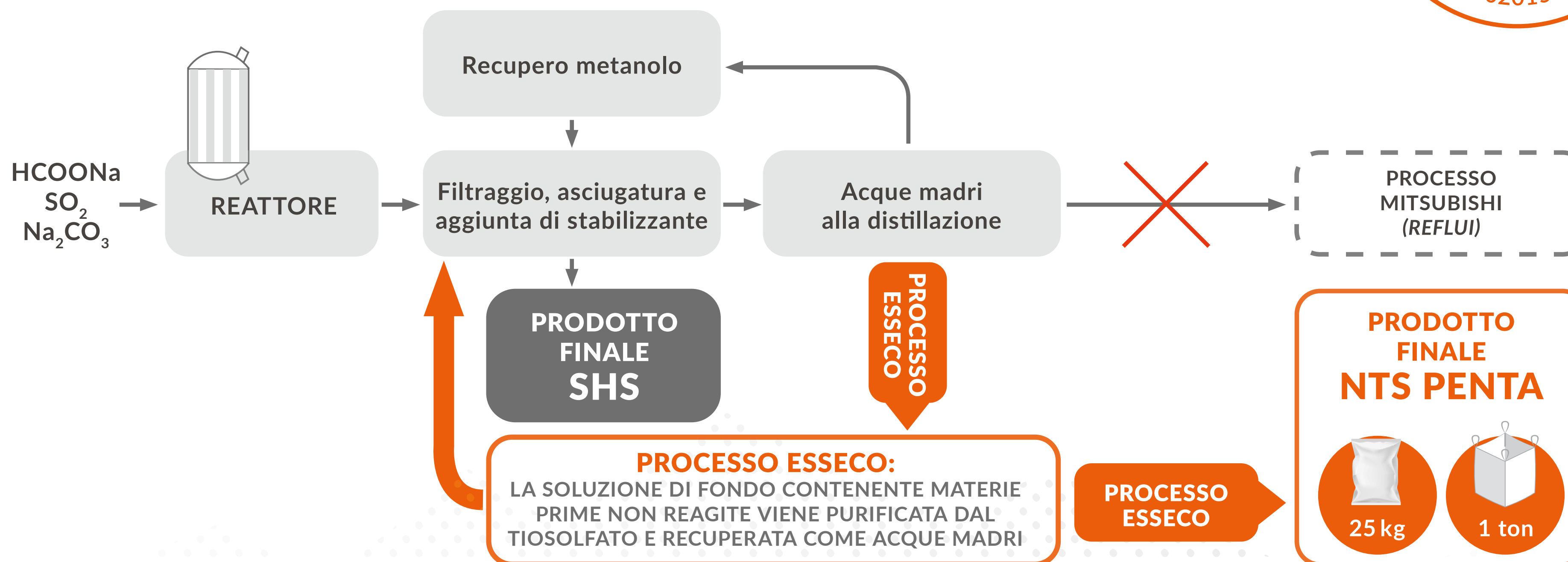

 **Drastica riduzione dell'impatto energetico**

Rispetto al più comune processo Mitsubishi, il brevetto **ESSECO** prevede la **purificazione delle acque madri** attraverso la separazione degli **NTS Penta**, che vengono poi riutilizzati nel ciclo produttivo.

 **Eliminazione sostanziale dell'impatto ambientale**



ECONOMIA CIRCOLARE

Derivati da Potassa Green con cattura CO₂

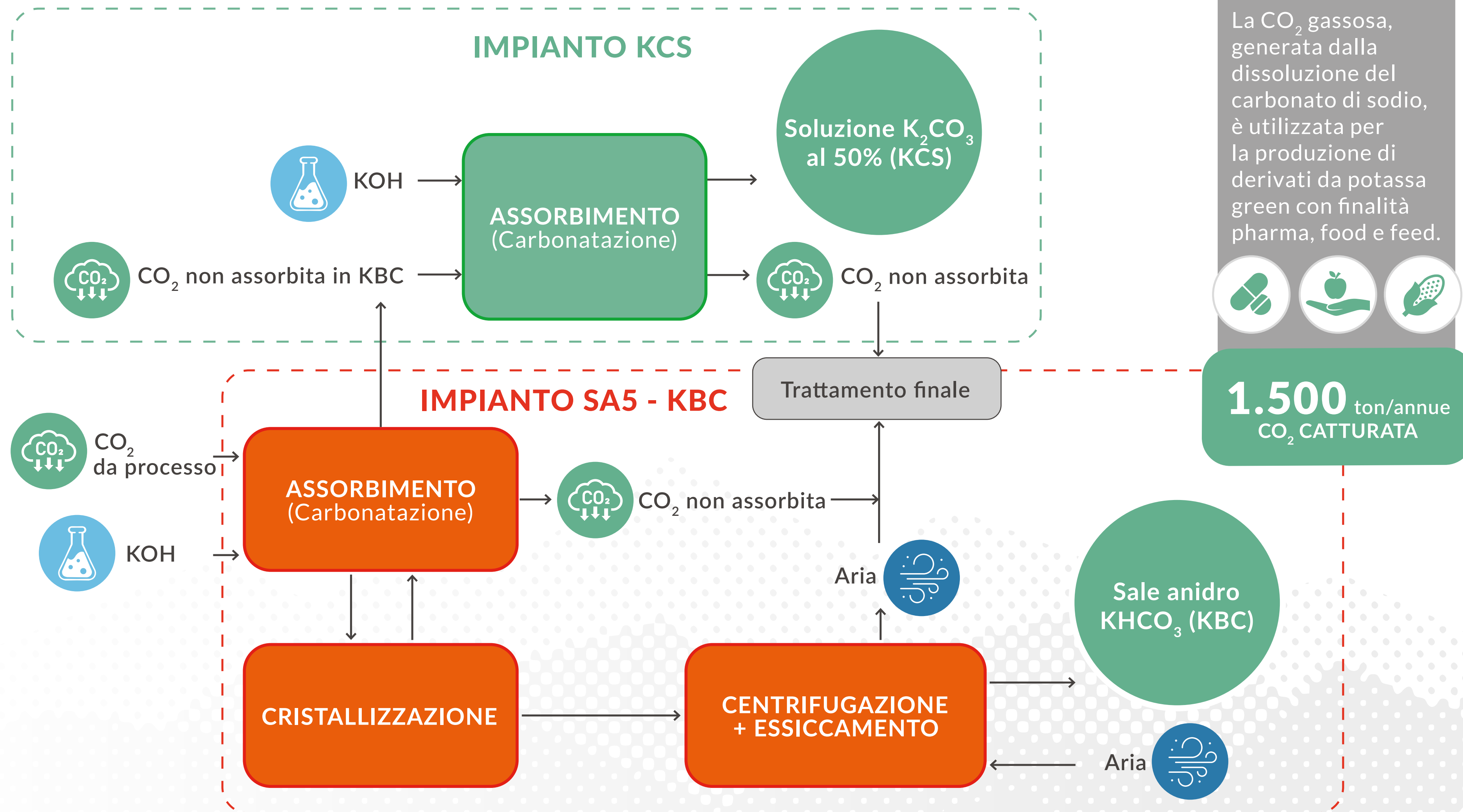

ECO-CHEM INNOVATIONS – GENESI

Mesi

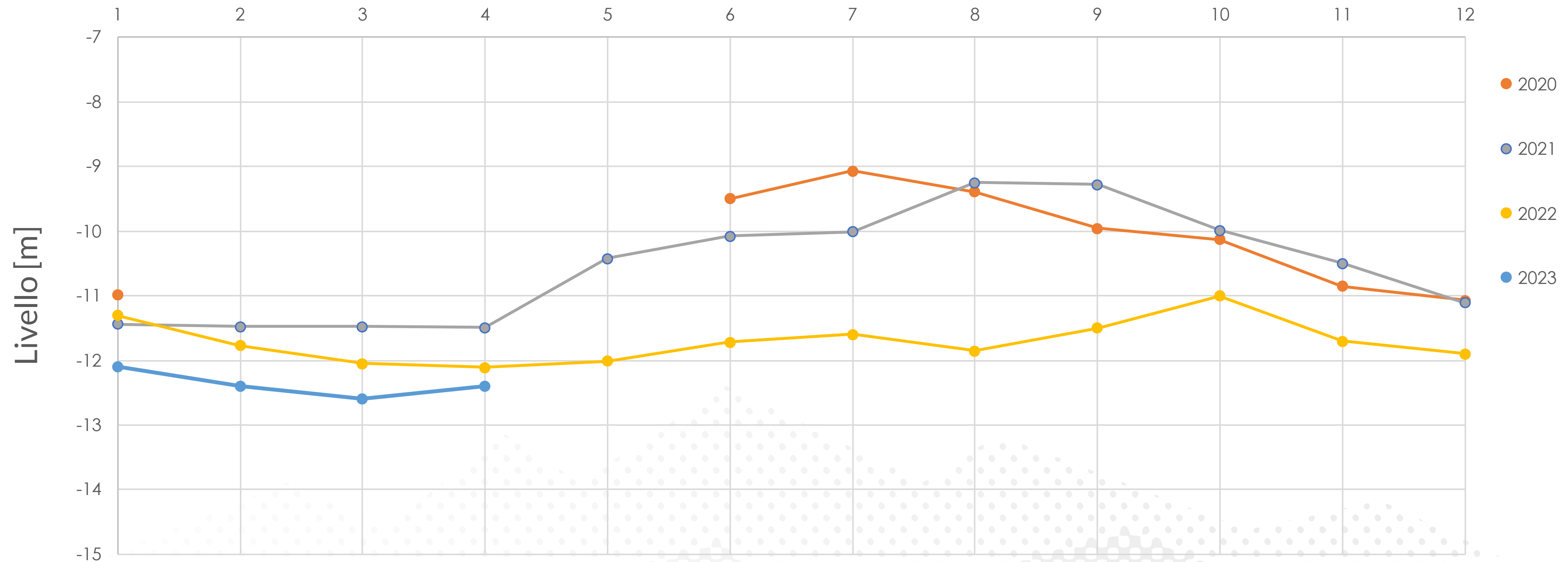

CRISI IDRICA

ECO-CHEM INNOVATIONS - PROGETTI



Acronimo Progetto: EcoChem Innovations

Titolo: EcoChem Innovations: Ottimizzazione Energetica e Produzione Avanzata

Durata del Progetto: 30 mesi

Valore complessivo dei progetti: 15,1 M€

Ritorno: 3 M€

Capofila: Esseco srl, in collaborazione

con 2 PMI piemontesi, Hysytech e Rams&s + UNITO e POLITO + Eascon



PROGETTO 1

Efficientamento Energetico (SOG/SL)

Obiettivo: riduzione dei costi energetici e dell'impatto ambientale.

Descrizione: mettere a punto una modifica strutturale di impianto che consenta da un lato il recupero di una cospicua frazione dell'energia di ossidazione dello zolfo attualmente dispersa rendendo lo stabilimento (che già in determinati periodi è capace di "esportare" quote di energia elettrica) ancora più efficiente dal punto di vista energetico e, dall'altro lato, di abbattere di un fattore di circa 30 volte l'emungimento annuale di acqua dalla falda profonda della pianura padana.

Parametri Tecnici: recupero di 200 kW di energia aggiuntiva, riduzione del consumo di acqua da 160 a 5 m³/h.



PROGETTO 2

Nuovo Impianto di Produzione di KPA

Obiettivo: aumento della capacità di produzione, miglioramento dell'efficienza operativa.

Descrizione: allargare lo spettro di prodotti disponibili per l'industria enologica sviluppando un impianto per la produzione su larga scala (1.600 ton/anno) di poliaspartato di potassio, KPA, un innovativo agente di origine naturale capace di bloccare la precipitazione dei tartrati, annoso problema dei processi di vinificazione.

Parametri Tecnici: passaggio da 5 m³ a 10m³ di capacità del batch, ottimizzazione delle condizioni operative.





Politecnico
di Torino

Our History

Technical School
for Engineers



1859

1862



Italian Industry
Museum

Regio Politecnico
di Torino



1906

1958



Corso Duca degli Abruzzi:
Campus opening

160 years of
Polytechnic Culture



2019



PoliTO Community (A.Y. 2024/2025)

1253

Teaching staff
(31% women)

1021

Administrative staff

38800

Students

8100

International students
(122 countries)

- **5925 first-year students** and **1450 PhD candidates**
- **50.6%** Italian students living outside Piedmont



25

Bachelor's degree programmes

4 in Architecture
21 in Engineering

37

Master's degree programmes

9 in Architecture
28 in Engineering

32

I and II level Specializing Master programmes and Lifelong Learning programmes

18

PhD programmes

5 in cooperation with other Universities (3) and research centers (2)

- PoliTo promotes various **initiatives to support the student community** (welcome week, accommodation..)
- **Best student cities:** Torino is among the world's most student-friendly locations according to QS Ranking



Departments



DENERG _ Department of Energy "Galileo Ferraris"

DIMEAS _ Department of Mechanical and Aerospace Engineering

DISAT _ Department of Applied Science and Technology

**Industrial Engineering
Area**

**Information Technologies
Area**



DAUIN _ Department of Control and Computer Engineering

DET _ Department of Electronics and Telecommunications



DIGEP _ Department of Management and Production Engineering

DISMA _ Department of Math, Sciences "Giuseppe Luigi Lagrange"

**Engineering and Management
and Mathematics for Engineering
Area**

**Civil and Environmental Engineering,
Architecture, Urban Planning and Design
Area**



DAD _ Department of Architecture and Design

DIATI _ Department of Environment, Land and Infrastructure Engineering

DISEG _ Department of Structural, Geotechnical and Building Engineering

DIST _ Interuniversity Department of Regional and Urban Studies and Planning



Department of Applied Science and Technology

- The Department of APPLIED SCIENCE AND TECHNOLOGY (DISAT) focuses on research and education involving the **fundamental principles of matter and energy, their transformation and related engineering applications.**
- The DISAT endorses, coordinates and manages fundamental and applied research, education and technology transfer.
- Topics: physics of condensed matter, nanotechnology, fundamental interactions, applied physics, chemistry, materials science and technology, metallurgy, failure analyses, materials and processes for bio-engineering
- **211 academic staff + 55 technical & administrative staff + 320 PhDs, post-docs & grant researchers, 70 external staff**



Thematic areas

- Food and sustainable process engineering
- Biomaterials, biomedical devices and pharmaceutical engineering
- Functional materials, micro e nano devices
- Ceramic metals and composites engineering
- Energy, environment and safety engineering
- Polymers, nanocomposites and textiles engineering
- Multiscale modeling for material science and process engineering
- Applied science for cultural heritage protection
- Particle physics and relativity
- Statistical and theoretical physics
- Quantum phenomena in condensed matter physics
- Computational biology and soft matter



Target: study of innovative chemical processes for developing a more sustainable society model

Staff: 18 academic members (13 permanent professors, 5 assistant professors) and 46 contract researchers (including 30 PhD students)

Biorefinery processes

- Production of fuels and chemicals from biomass by using renewable sources

Chemical and catalytic processes for energy and environment

- Catalytic and photocatalytic abatement of pollutants from gaseous and aqueous streams
- Catalysis for CO₂ hydrogenation

Sustainable processes for the agri-food industry

- monitoring of the quality and safety of products of the food industry

Life Cycle Analysis (LCA) of new technologies and chemicals

CO₂ reduction for a low-carbon economy

- Use of CO₂ for the production of high-added value products (chemicals and fuels)
- Development of new technologies per the reduction of CO₂ emissions
- Re-use, recovery and valorisation of waste for limiting the environmental impact of conventional processes



CREST attività con aziende

- Consulenza su tematiche tecnologiche di frontiera
- Sviluppo di nuovi materiali nell'ambito della catalisi per applicazioni ambientali ed energetiche
- Sviluppo di nuovi processi nell'ambito della sostenibilità e circolarità
- Caratterizzazione chimico-fisica di materiali e prodotti
- Ottimizzazione di processi già esistenti
- Trasferimento tecnologico

Il progetto di **efficientamento energetico** nella produzione di anidride solforosa punta, da un lato, ad un ulteriore recupero di energia termica dal processo di combustione dello zolfo e, dall'altro, ad una significativa riduzione del consumo di acqua di pozzo attraverso un innovativo processo a ciclo chiuso.

Fino a 400 kW
equivalente ad un
risparmio di 1000 m³
giorno di metano con
una riduzione di 1,8 t/
giorno di CO₂



Fino a 160 m³/h di
acqua di pozzo
recuperata per almeno
sei mesi l'anno



ECO-CHEM INNOVATIONS - PRODUZIONE DI SO₂ IN CIRCUITO CHIUSO

CON RIDUZIONE EMUNGIMENTO ACQUA DA FALDA PROFONDA

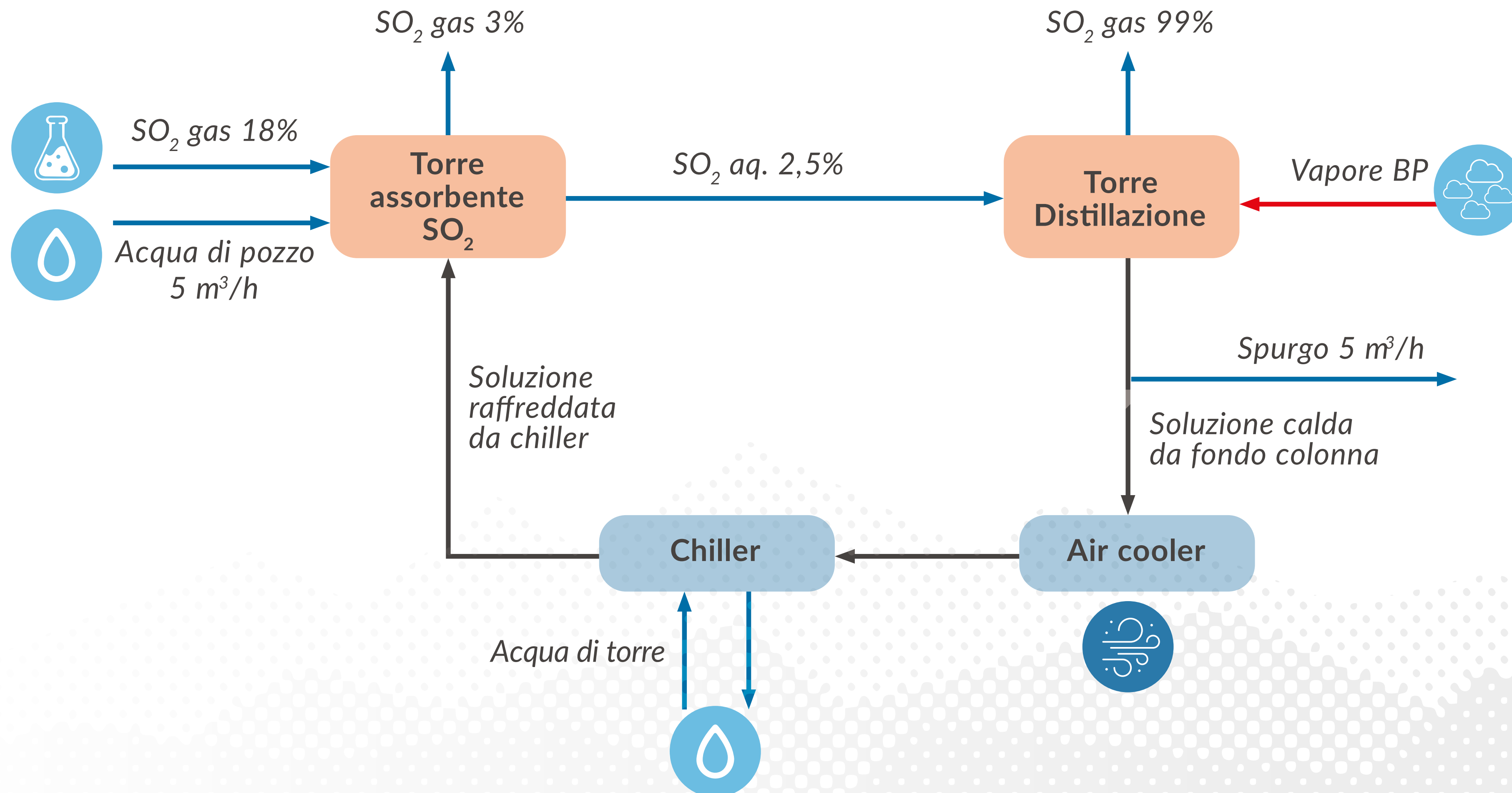

ECO-CHEM INNOVATIONS – RECUPERO DI CALORE SOG₃

CONFIGURAZIONE ATTUALE

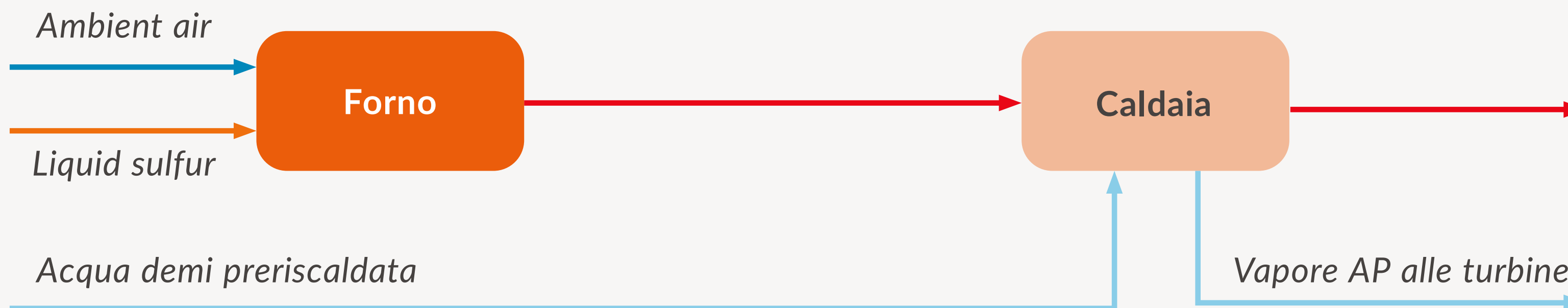

CONFIGURAZIONE FUTURA

Additional ≈ 2 t/h of HP steam gained thanks to gas-gas exchanger

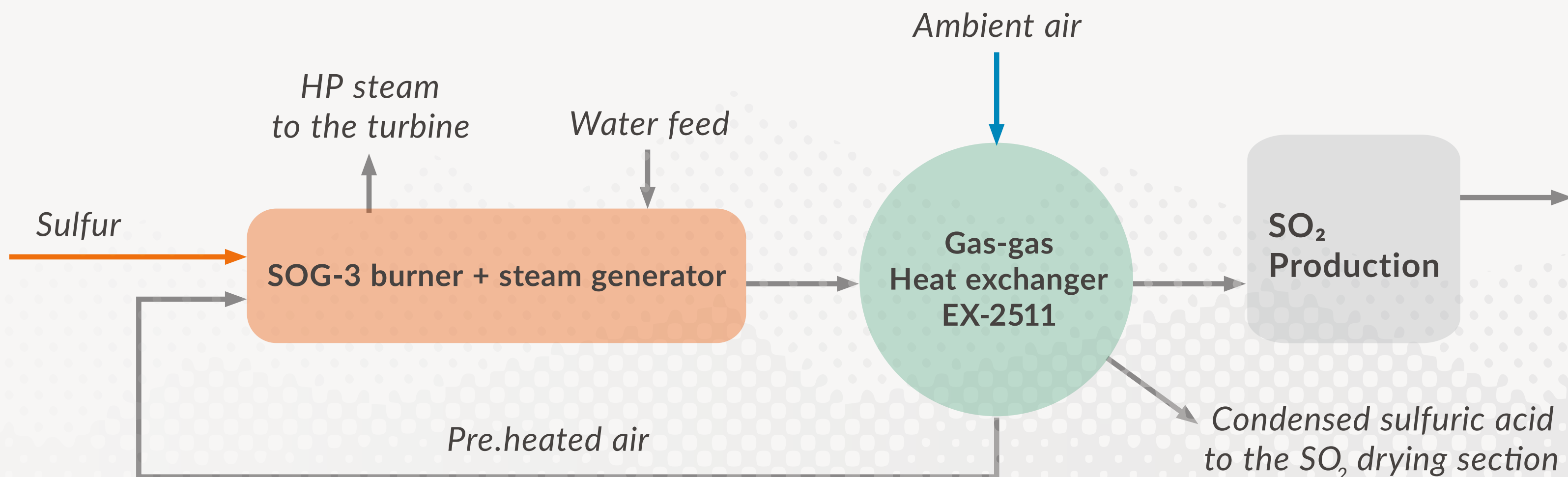

PROGETTI FUTURI: REPOWERING TURBINA

Le diverse progettualità precedentemente descritte, che puntano al potenziamento produttivo, fanno sì che si renda necessario il **repowering della turbina KKK**, con installazione di una nuova turbina a condensazione in grado di poter beneficiare degli sviluppi e di ricevere 20.000 kg/h di vapore ad alta pressione, con una reale attesa di 4.100 kWh, affinché si possa assorbire l'attuale produzione energetica del cogeneratore.





CREST nel progetto ECOCHEM Innovations

- Raccolta dati di processo
- Analisi del processo in termini di materia ed energia e verifica dei bilanci
- Creazione di un modello digitale (descrittivo e successivamente predittivo) tramite software di simulazione di processo
- Attività di debottlenecking e «what if»
- Analisi di fattibilità dell'integrazione energetica e verifica tramite modello digitale

ECO-CHEM Innovations: esempi di risultati

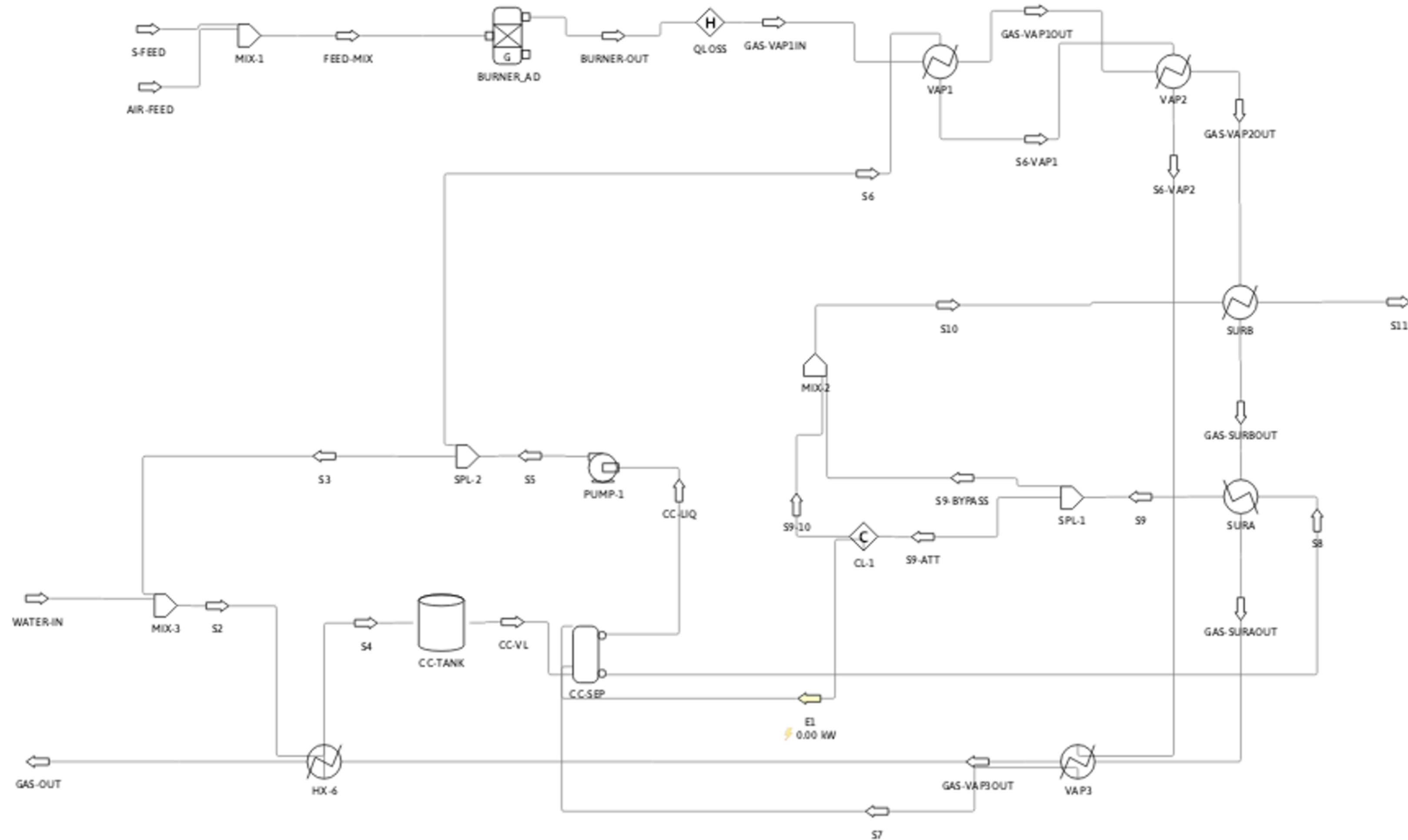

ECO-CHEM Innovations: esempi di risultati

Effetto del rapporto O₂/S in alimentazione

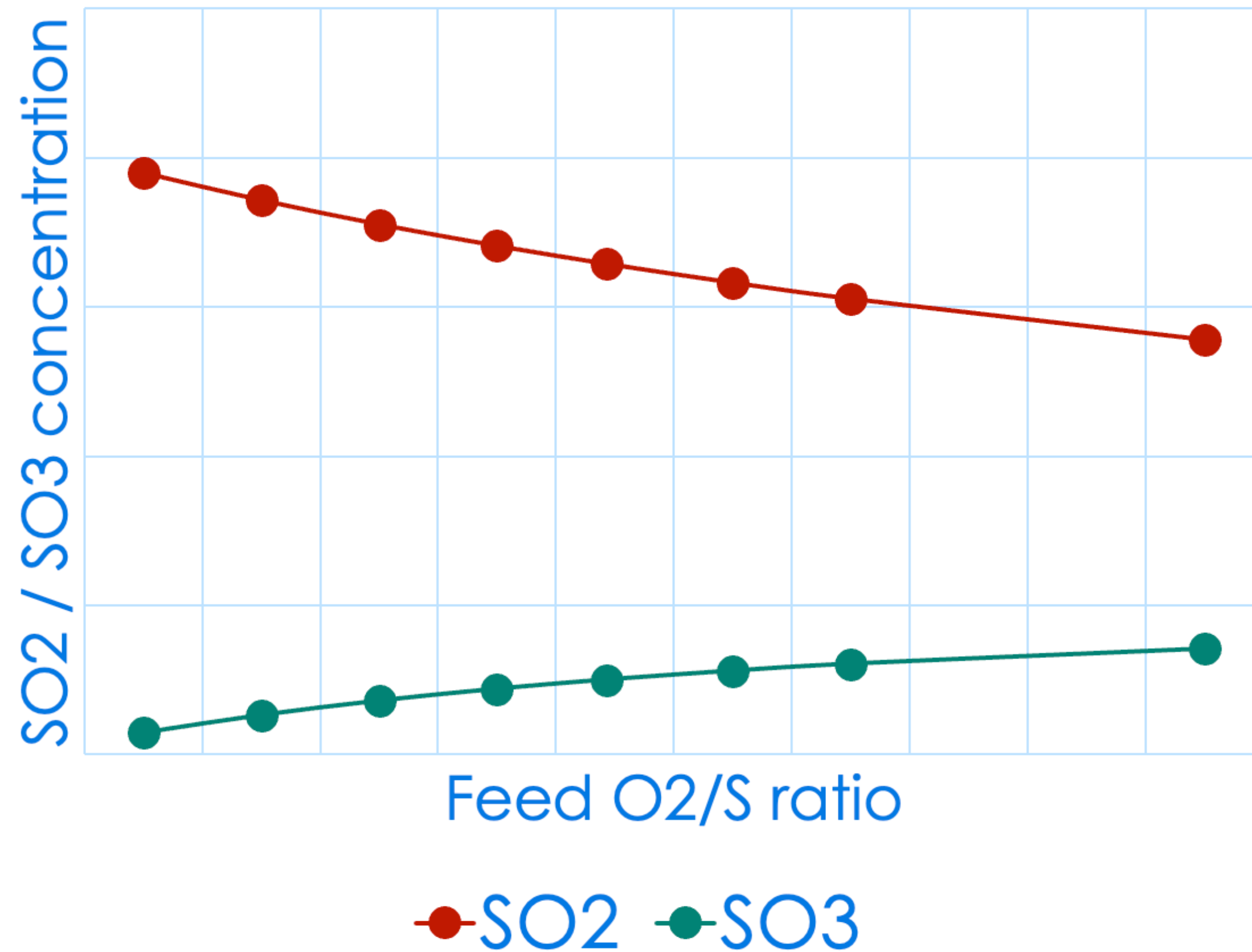

Effetto della temperatura di alimentazione

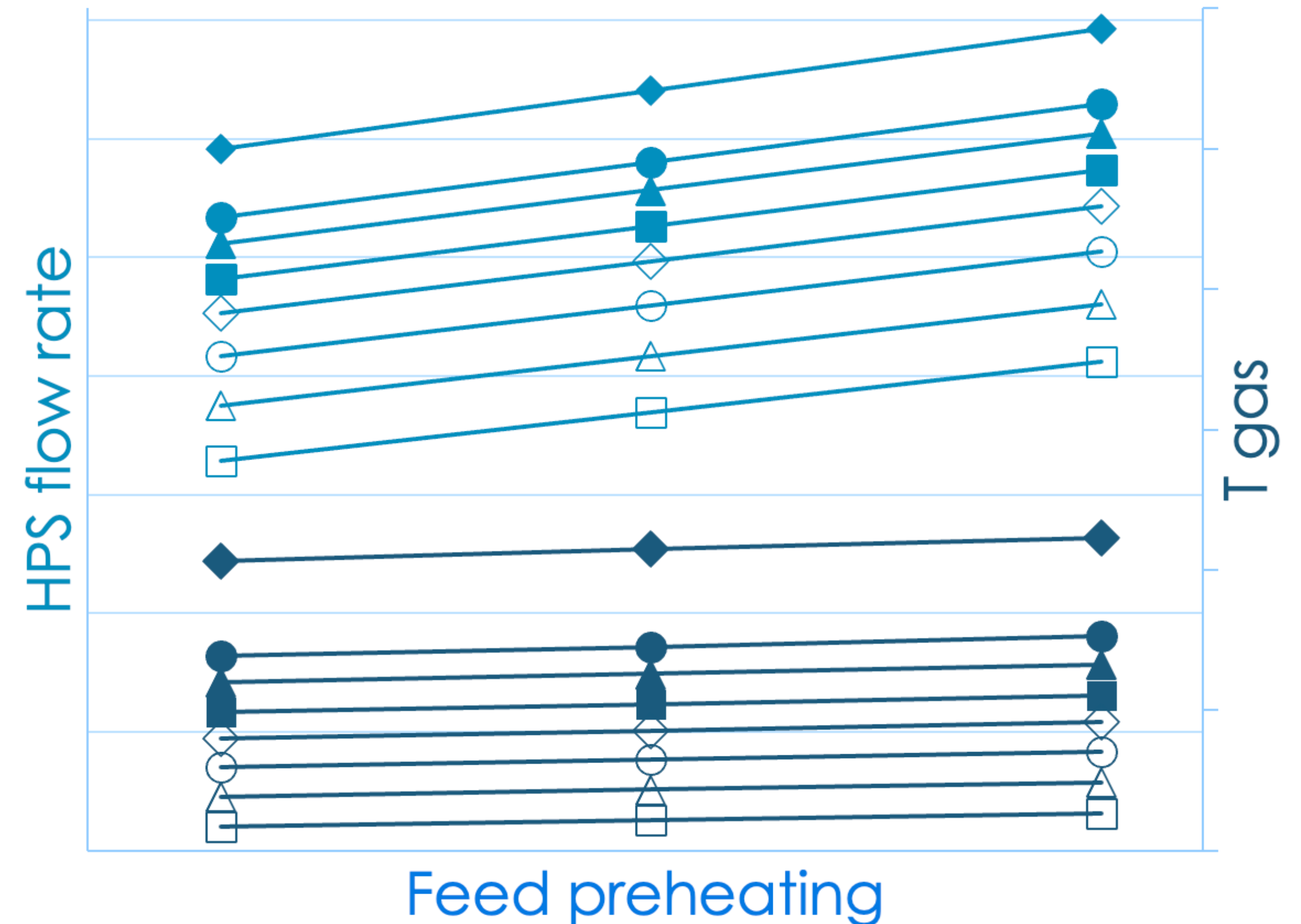



**Politecnico
di Torino**
International
University

GRAZIE PER L'ATTENZIONE

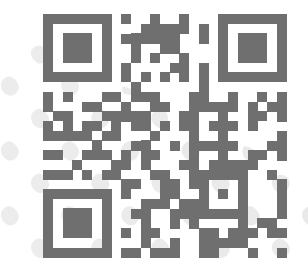

www.esseco.com
[linkedin.com/company/esseco-italia/](https://www.linkedin.com/company/esseco-italia/)

www.essecoindustrial.com



A COMPANY OF ESSECO INDUSTRIAL